

Parts List			
Item	Qty	Part Number	Material
1	1	Tool Post	Steel
2	2	Clamping Cylinder	Brass
3	1	Post Cam	Steel
4	1	Post Sleeve	Steel
5	1	Tool Holder	Steel
6	1	Boring Bar Holder	Steel
7	1	Swivel Bar	Steel
8	5	92610A245	Steel
9	2	91375A252	Steel
10	2	90480A011	Steel
11	2	Knurled Height Adjust Nut	Brass

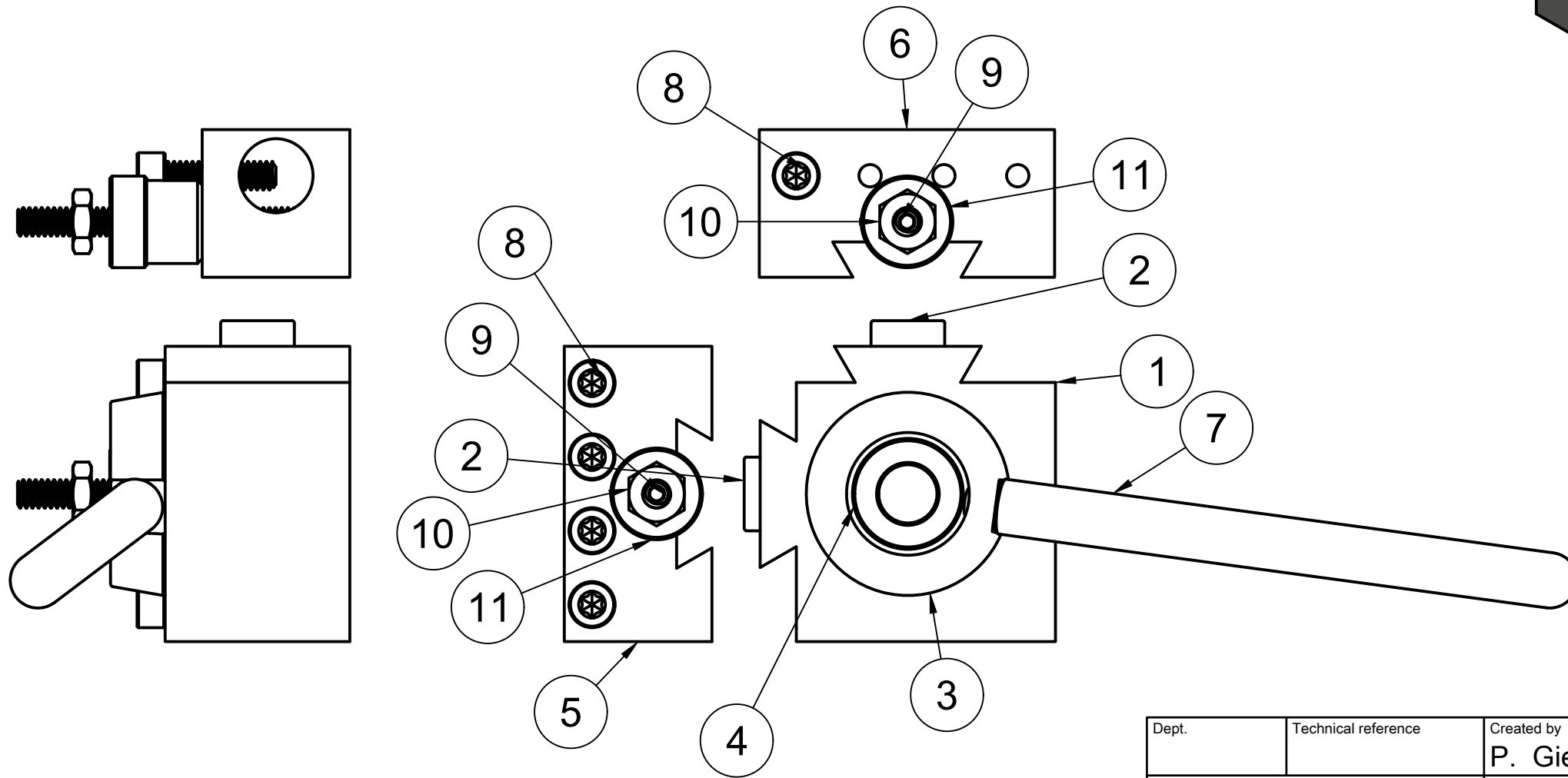
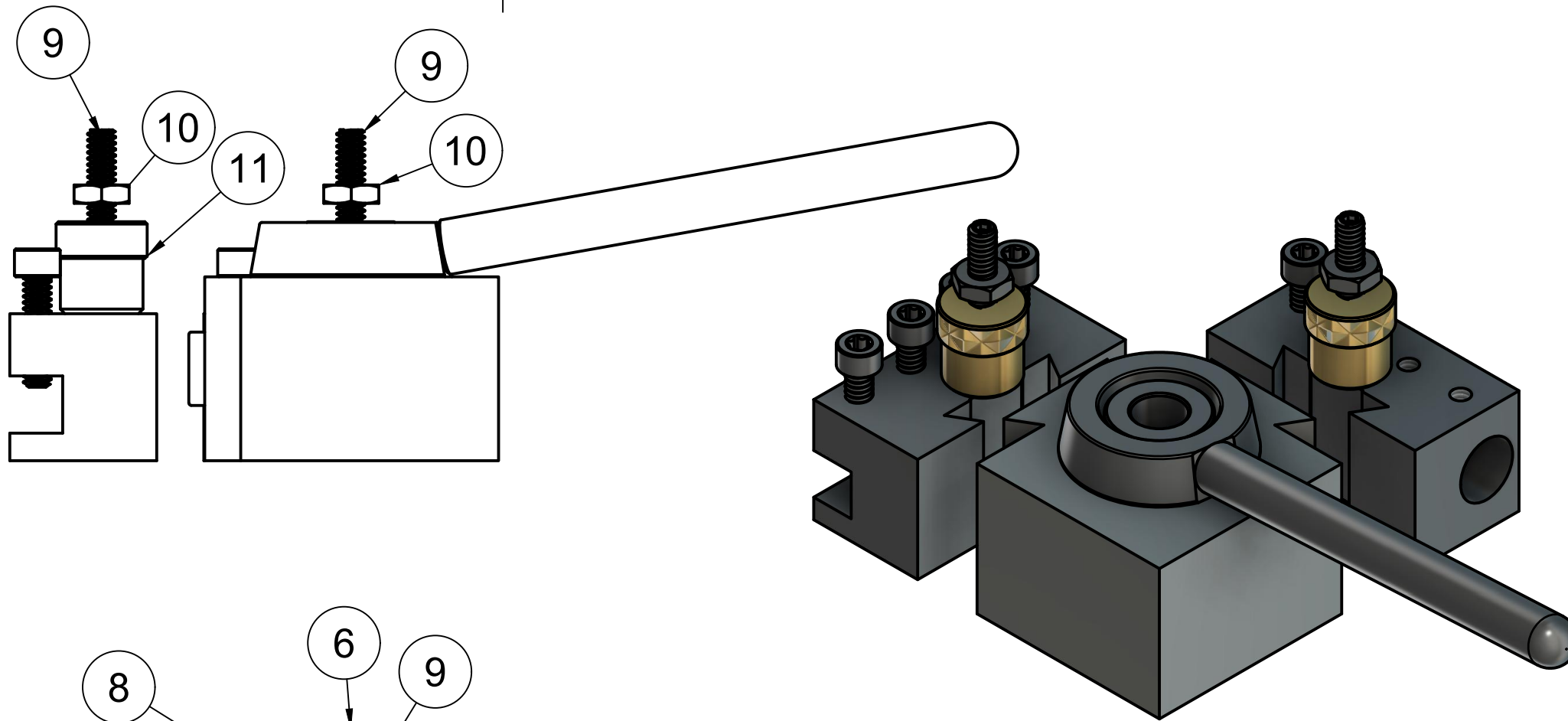

NOTES:
 - Main Post through hole is 10mm to match mini lathe 10mm threaded rod to mount tool post.
FASTENERS REQUIRED
 - 10-24 X 3/4" UNC Socket Head Cap Screws - 16- 20 pieces
 - 10-24 UNC X 2" - Screws or Set screws
 - 10-24 UNC Nuts - 4 to 6 pieces
 (not all shown in design)

Dept.	Technical reference	Created by P. Giesbrecht 4/20/2019	Approved by
THE AMATEUR MACHINE SHOP		Document type	Document status
		Title Quick Change Lathe Tool Assm	DWG No.
Rev.	Date of issue	Sheet	1/1